

DESIGN INFORMATION

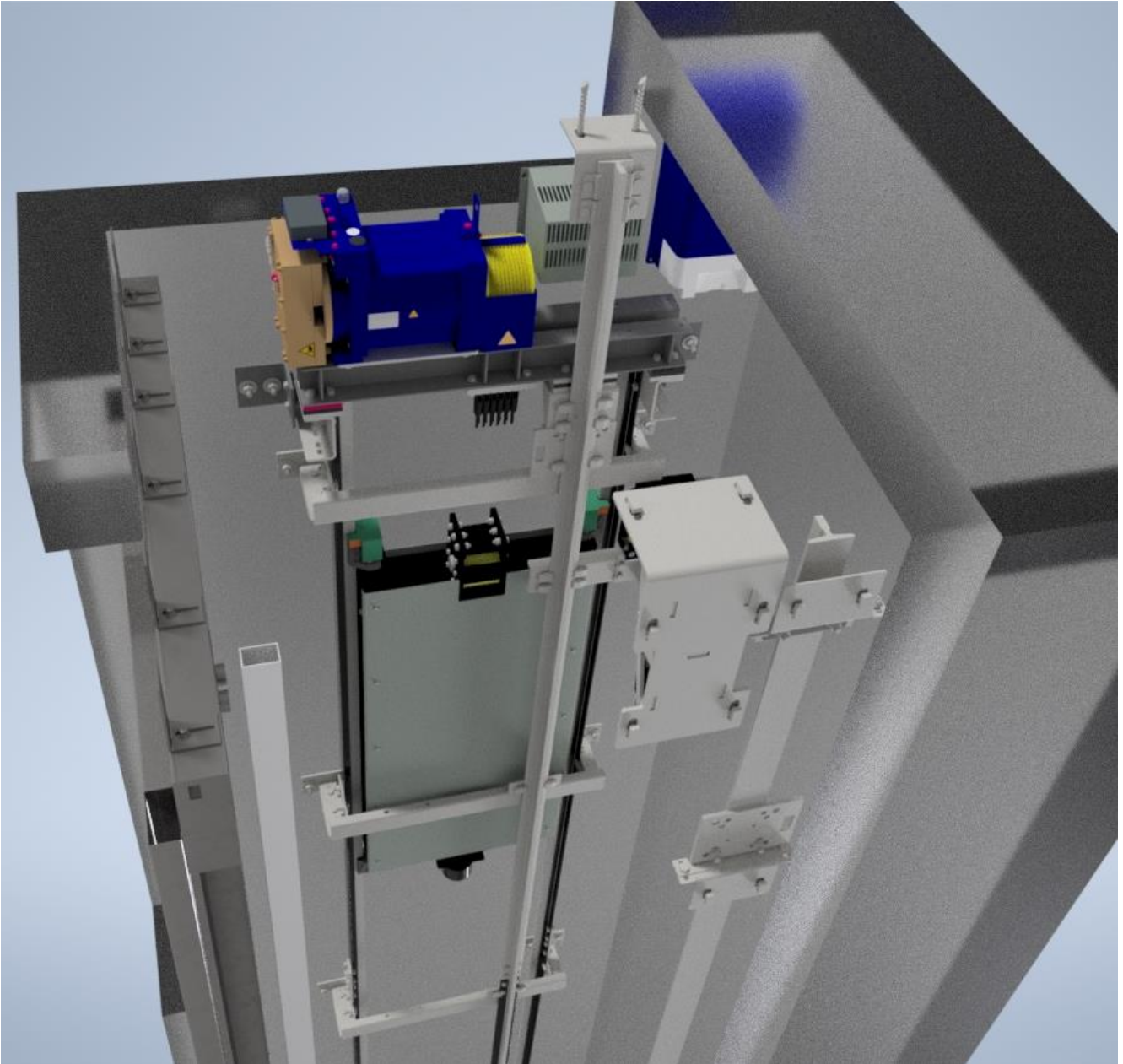

CAR FRAME KIT - CENTRAL FRAME

TYPE: ZZE-S

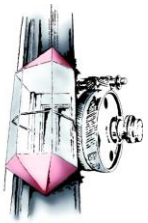
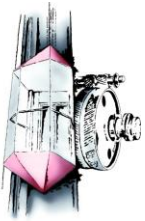

TABLE OF CONTENTS

DESIGN INFORMATION	1
CAR FRAME KIT - CENTRAL FRAME	1
Type: ZZE-S	1
TABLE OF CONTENTS	2
1 SAFETY INSTRUCTIONS	3
2 INQUIRY CAR FRAME KIT ZZE-S (CENTRAL FRAME ROPE)	4
OptionS	5
3 Type of car frame	6
3.1 CENTRAL FRAME KIT ZZE-S-1600	7
4 SPECIAL FEATURES / ADDITIONAL SAFETY MEASURES	9
HINTS:	9



1 SAFETY INSTRUCTIONS

THIS DOCUMENTATION CONTAINS VARIOUS SYMBOLS WHICH CORRESPOND TO IMPORTANT SAFETY INSTRUCTIONS AND MUST BE OBSERVED:



IMPORTANT: INDICATES APPLICATION TIPS AND OTHER SPECIAL USEFUL INFORMATION.



Warning!

To draw attention to a risk that could result in serious personal injury or death.



Danger!

To draw attention to an imminent danger that will result in serious personal injury or death.



Caution!

To draw attention to a hazardous or unsafe practice which could result in personal injury or property damage.



Watch out!

Indicates a potentially harmful situation. If not avoided, the product or something in its vicinity may be damaged.

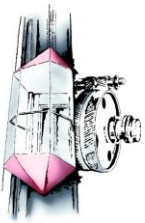

2 INQUIRY CAR FRAME KIT ZZE-S (CENTRAL FRAME ROPE)

Company:	E-Mail:
Name:	Phone:
Project	Delivery date:

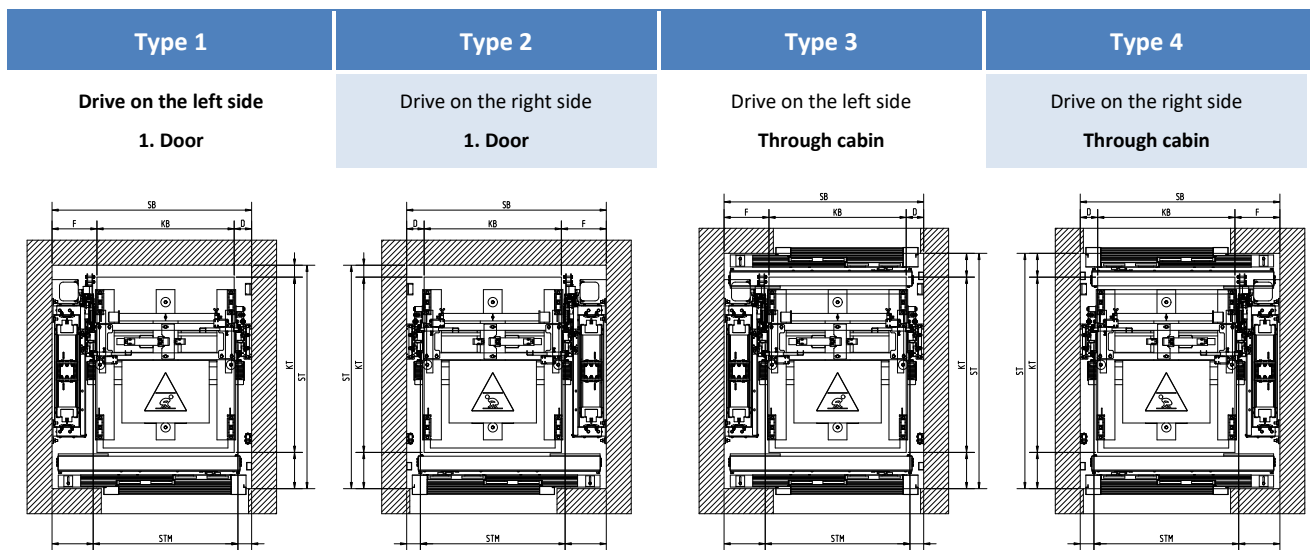

<i>Person lift</i>			<i>Goods lift</i>			
<i>Load capacity</i>	Q	kg		<i>Car width inside</i>	KBI	mm
<i>Cabin weight 1)</i>	PK	kg		<i>Car depth inside</i>	KTI	mm
<i>Car travel</i>	FK	mm		<i>Car height inside</i>	KHI	mm
<i>Car overtravel bottom</i>	RHU	mm		<i>Car width outside</i>	KB	mm
<i>Car overtravel top</i>	RHO	mm		<i>Car depth outside</i>	KT	mm
<i>Car speed 2)</i>	v	m/s		<i>Car height outside</i>	KH	mm
<i>Shaft width inside</i>	SB	mm		<i>Car roof 3)</i>	KD	mm
<i>Shaft depth inside</i>	ST	mm		<i>Car floor 4)</i>	KU	mm
<i>Shaft head</i>	SK	mm		<i>Distance between guides 5)</i>	STM	mm
<i>Shaft pit</i>	SG	mm		<i>Dist. to wall drive side 5)</i>	F	mm
<i>1.Bracket spacing/Pit</i>	B1	mm		<i>Dist. To wall without drive 5)</i>	D	mm
<i>Maximum bracket spacing</i>	B2	mm				

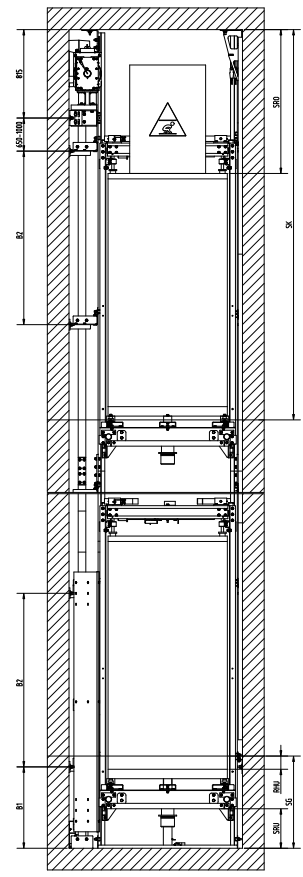

- 1) Weight without kit frame, but including doors and traveling cable
- 2) Nominal speeds up to max. 1.6 m/s possible (at speeds over 1m/s the shaft dimensions increase; these can be requested from our sales department)
- 3) without information 50 mm
- 4) without information 100 mm
- 5) Pitch and wall distances are determined by Berchtenbreiter GmbH

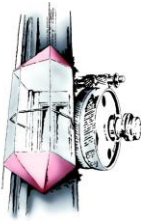

OPTIONS

Type of safety gear

Wittur CSGB

Cobianchi PC13GO

Wittur ESG-17/25

Safety gear release system

OG-Jungblut with remote control 230 V/DC

Elgo Limax 33CP

other

New Lift FST3 (S2)

OG and tension weight by customer

Guide shoes

ETN PE

ETN PEPU (muted)

Roller guides (fixed) **1)**

Additional safety measures

Shaft head

Shaft pit

1) With roller guides, the shaft dimensions increase. These can be requested from our sales department



3 TYPE OF CAR FRAME

Central frame indirectly with drive in the shaft head

1. ZZE-S1600



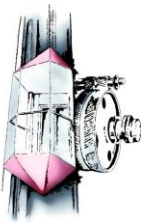

3.1 CENTRAL FRAME KIT ZZE-S-1600

Type 1: Drive left side 1 door

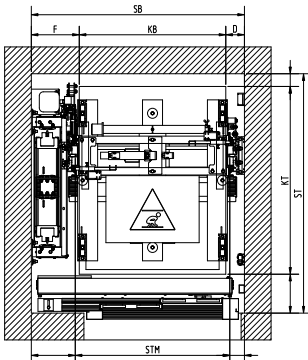

Type 2: Drive right side 1 door

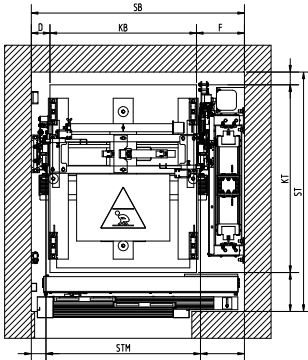

Type 3: Drive left side through cabin

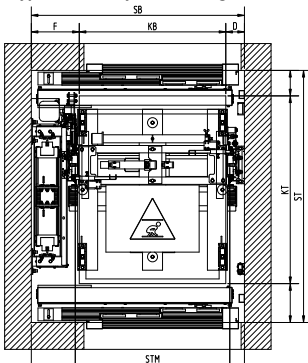

Type 4: Drive right side through cabin

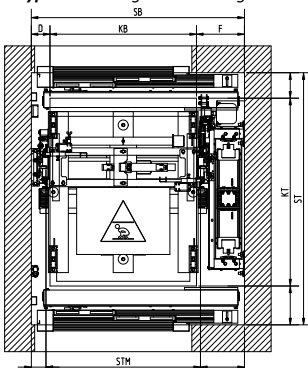

Mirrored position possible

ZZE-S 1600

Load capacity max.	Q	kg	675
Car weight (without car frame)	PK	kg	
Q + PK max.		kg	1750
Car frame weight	PB	kg	220-260
Guide rails cabin		mm	T 89/62/16
Guide rails counterweight		mm	T 70 /65 / 9
Drive	SM 180.24B	kg	170
	SM 180.35B	kg	195
Traction sheave Ø		mm	240
max. 8 ropes Ø6,5 mm	Drako 250T or Wolf PAWO 819 W		
Pulley diameter Ø160 8x6,5	Plastic rollers		
Guide shoes	ETN HSM 140 or roller guides		
Buffer	P+S or Henning		
Overspeed governor	Standard => Jungblut (Bode, PFB)		

Shortcuts

Car width inside	KBI	Shaft width inside	SB
Car depth inside	KTI	Shaft depth inside	ST
Car width outside	KB	Shaft head	SK
Car depth outside	KT	Shaft pit	SG
Car roof	KD	Shaft height	SH
Car height inside	KHI	1.Bracket distance / pit	B1
Car floor	KU	Max. bracket distance	B2
Car height outside	KH	Distance between guides	SM
Car Travel	FK	Buffer pillar	PS
Car overtravel (top)	RHO	Buffer stroke	PH
Car overtravel (bottom)	RHU	Buffer height complete	H
Distance guides (Car frame)	FA	Safety distance top	SRO
SRO Safety distance (top)	XO	Safety distance bottom	SRU

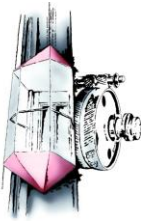

Central car frame ZZE-S-1600

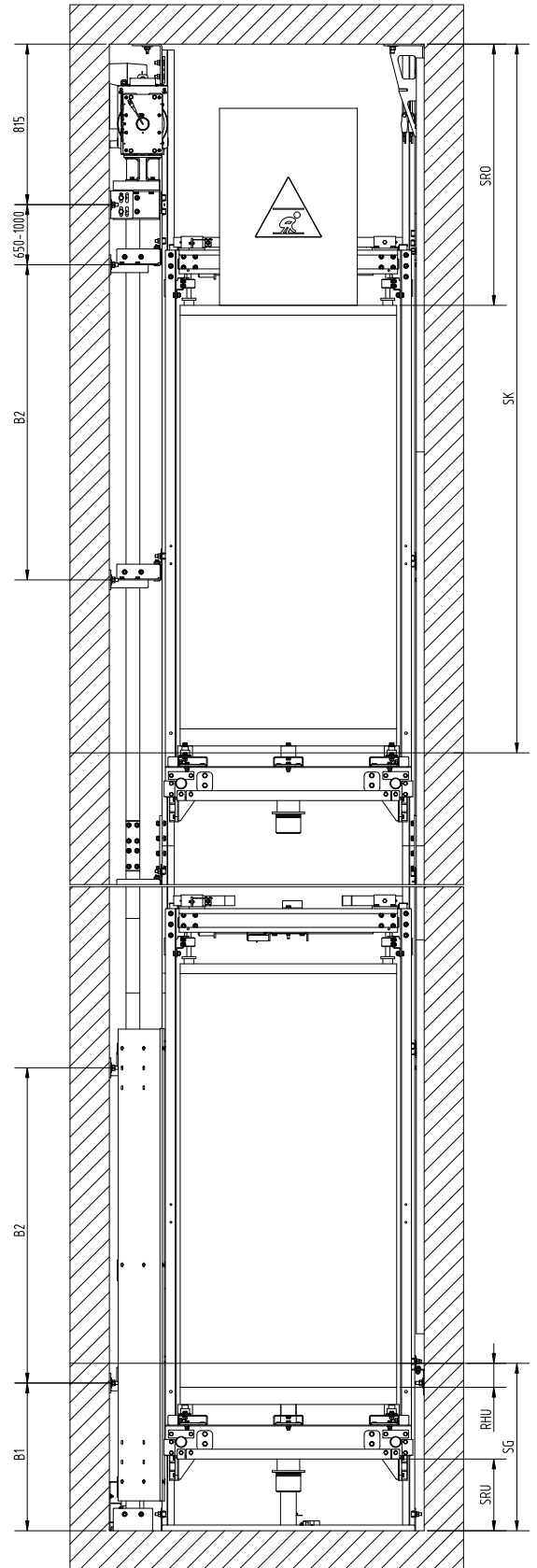
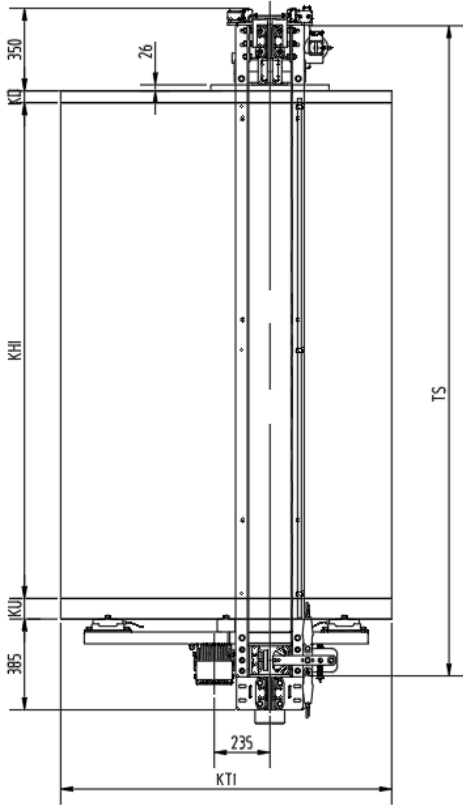

Shaft dimensions (mm)

Shaft width (SB)	Cabin width (KB)	Dist. Betw. rails (STM)	Wall-STM drive (F)	Wall-STM (D)
min.1600	at 1100	1160	330	110
1600-1650	1100	1160-1210	330	110
1650+ x	1100	1210	330	110+ x

* With a shaft width greater than 1650 mm, the distances from the wall to the cabin on the car side (≤ 300 mm (EN81:20-5.4.7.4)) must be observed. Should a 700mm or 1100mm guardrail be required, the headroom must be raised.

* With a cabin smaller $KB = 1100\text{mm} \times KT = 1400$, the shelters and the installation of the overspeed governor and the tension weight must be checked.

Shaft pit

Depth of shaft pit (SG)	anti-vibration beam	Safety gear
≥ 400 mm (KU ≤ 60)	no	Wittur ESG-25U
≥ 505 mm (KU ≤ 60)	yes	Wittur ESG-25U
≥ 750 mm (KU ≤ 100)	no	Wittur CSGB01
≥ 855 mm (KU ≤ 100)	yes	Wittur CSGB01
≥ 750 mm (KU ≤ 100)	no	Cobianchi PC13GO
≥ 855 mm (KU ≤ 100)	yes	Cobianchi PC13GO

* minimum shaft pit 400 mm with a maximum floor thickness of 60 mm (floor incl. covering)



Minimum shaft head in relation tot he shaft pit (Load 630kg)

Shaft head (SK)	Shaft pit (SG)	Counterweightfill level	Car weight (PK)
2600 mm	400 mm	1250 mm	850 kg
2700 mm	400 mm	1350 mm	925 kg
2800 mm	400 mm	1450 mm	970 kg
2600 mm	500 mm	1350 mm	925 kg
2600 mm	600 mm	1450 mm	970 kg

- * Counterweight filling height for SG=400/SK2600 maximum 1250 mm (filling 150x710) with more shaft head or shaft pit the counterweight level can be increased proportionally
- * Minimum shaft head 2600 mm with a cabin height of 2100 mm (door height 2000 mm)
- * with anti-vibration metal insulation at the top, +50 mm shaft head is required
- * Construction tolerances pit/headroom -0 mm 20 mm

4 SPECIAL FEATURES / ADDITIONAL SAFETY MEASURES

ADDITIONAL SAFETY MEASURES IN THE SHAFT PIT

- With Wittur ESG 17/25 with NEW FST 3 (S2) or Limax 33CP with sink prevention Bode or Jungblut
- Push-in support in the pit and 2 additional limit switches in the shaft pit

ADDITIONAL SAFETY MEASURES IN THE SHAFT HEAD

- Contact-monitored folding support on the upper beam
- No further limit switches are required for NEW FST 3 (S2) or Limax 33CP without the NEW FST 3 (S2) or Limax 33CP, there are 2 limit switches in the shaft head and 2 independent ones Switching lugs required on the safety frame

HINTS:

Additional safety measures at a speed greater than 1.0 m/s are only possible with a deceleration control circuit. A control circuit according to "SIL 3" should preferably be used here.

If a frame control with shaft box is used or an EVAC is used, there are new shaft dimensions.

INFO@BERCHTENBREITER-GMBH.DE

WWW.BERCHTENBREITER-GMBH.DE

© 2020 by Berchtenbreiter GmbH, D-86637 Rieblingen

All rights reserved

All rights reserved.

The specified data is used solely for the product description and is not to be understood as guaranteed properties in the legal sense. The information does not release the user from making his own assessments and tests. Due to continuous improvement of the products, the product specifications made in this catalog are subject to change.